

BABY LOCK SEWING ACCESSORIES

Buttonhole Foot

(BLG-BH)

Instructions

When it comes to buttonholes, the perfect fit is key. This snap-on foot measures your button for you with a clamp system, so you'll sew even-sized and precise buttonholes every time! The built-in thread guides will even allow you to create corded buttonholes!

INSTRUCTIONS:

1. One-step buttonholes are sewn from the front of the presser foot to the back. See diagram shown below for the expanded view of the stitch direction.

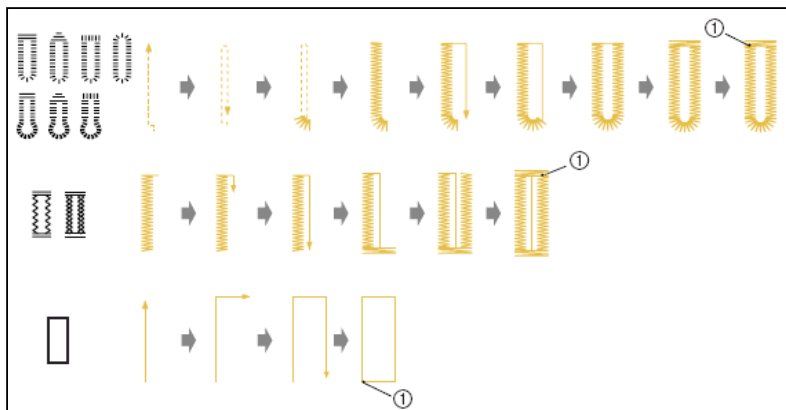

2. Select a buttonhole stitch, and attach Buttonhole Foot "A".



3. Mark the position and length of the buttonhole on the fabric.

Note: The maximum buttonhole length is about 28 mm (approx. 1-1/16 inches) (diameter + thickness of the button).

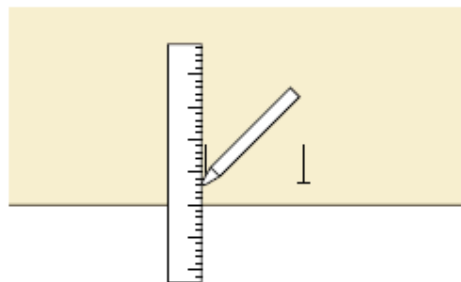

4. Pull out the button holder plate on the presser foot, and insert the button that will be put through the buttonhole. Then tighten the button holder plate around the button.

Note: The size of the buttonhole is decided by the button holder plate holding the button.

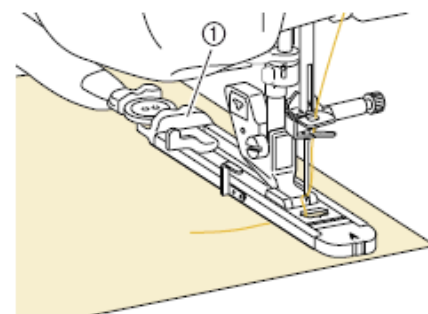

① Button holder plate



FOR THE LOVE OF SEWING

5. Align the presser foot with the mark on the fabric, and lower the presser foot.

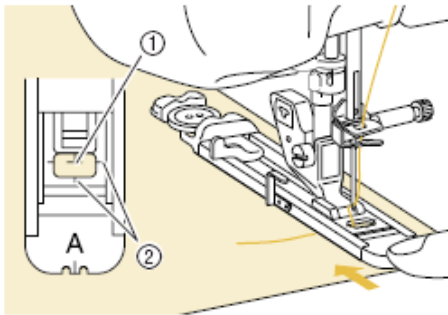

- ① Mark on the fabric
- ② Marks on the presser foot

Note: Pass the thread underneath the presser foot. Slide the outside frame of the buttonhole foot backward as far as possible as shown in the illustration, making sure that there is no gap behind the part of the foot marked "A". If the buttonhole foot is not slid back as far as possible, the buttonhole will not be sewn at the correct size.

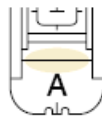

6. Lower the buttonhole lever so that it is positioned behind the metal bracket on the buttonhole foot.

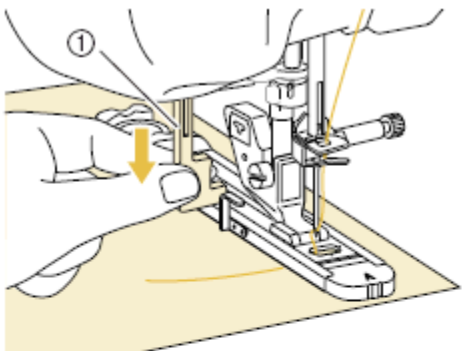

7. Gently hold the end of the upper thread, and then start sewing. Feed the fabric carefully by hand while the buttonhole is sewn.

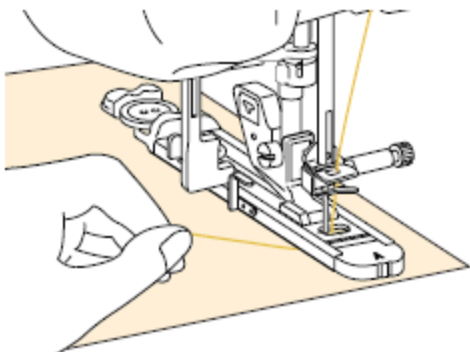

8. Once sewing is completed, the machine automatically sews reinforcement stitches, and then stops.
9. Insert a pin along the inside of one of the bar tacks, and then insert the seam ripper into the center of the buttonhole and very carefully cut towards the pin.

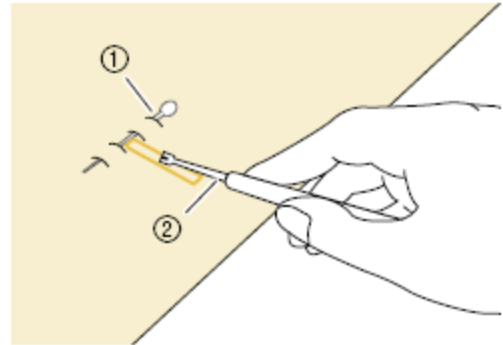

- ① Basting pin
- ② Seam ripper



FOR THE LOVE OF SEWING

800-422-2952

www.babylock.com