

## “Spring Quilted Lily Wall Hanging”



Lilies will spring to life with this spring quilted wall hanging. The designs were taken from the Nancy Zieman Exclusive Collection built into the Ellisimo sewing and embroidery machine. With CustomWorks to merge and edit, and along with SizeWorks to resize certain designs, the wall hanging came together to create this stunning quilt.

**Skill Level:** Advanced

**Created by:** Diane Kron, Software and Embroidery Project Manager

**Supplies:**

Baby Lock® Ellisimo sewing and embroidery machine using the 200mm x 300mm hoop

CustomWorks from Designer's Gallery®

SizeWorks from Designer's Gallery

1 ½ Yards of light green print for background and backing fabric

1 Yard dark green print that has the appearance of stems

1 ½ Yard of purple marbled Moda print fabric

1 Yard white organza

Baby Lock® Tear-Away stabilizer

Baby Lock Hydro Melt Topping

Temporary spray adhesive

Wood burning tool

Sewing and embroidery thread

General sewing and embroidery supplies

**Instructions:**

Turn the Ellisimo sewing and embroidery machine on and retrieve all of the lily designs one at a time. Save each of the designs to a thumb drive that you attached to high speed USB slot on the right side of the machine. Follow the manufacturer's directions for saving the designs to the thumb drive.



The following directions will be written starting with the top block and working downward.

All assembly will use a ¼" seam allowance.

The finished size of the wall hanging is 21" x 44"

**Block 1:**



1. Open the program by clicking on the CustomWorks  icon on the desktop.
2. To place the hoop on the workspace, click on menu View and click on Select Hoop. Select the 200mm x 300mm hoop. Click OK.
3. Click on the Grid  icon to place the grid on the workspace.
4. Click on the Merge icon and select the single leaf design (*as shown in the illustration below*).

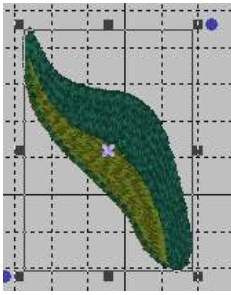

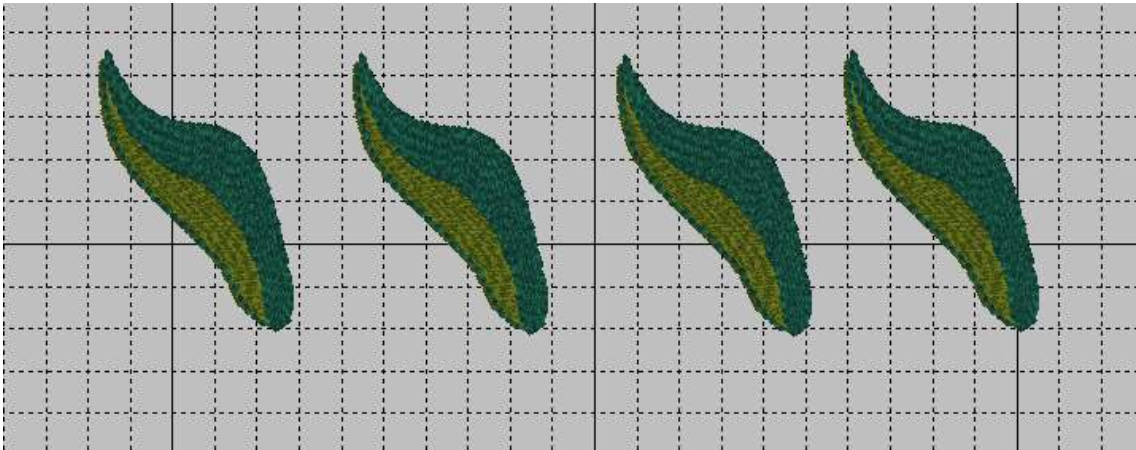

5. With the design on the workspace, left click on the design to select. In the Properties field, change the size of the design by typing in 65mm in the Height field and Apply. Since SizeWorks is installed, it becomes part of the program and is being utilized. To duplicate the design, right click on the selected design and choose Copy from the list of commands. Right click again and choose Paste. The Duplicated design will be selected. Move the design to the right of the original design leaving approximately a 1½" gap between the two designs.

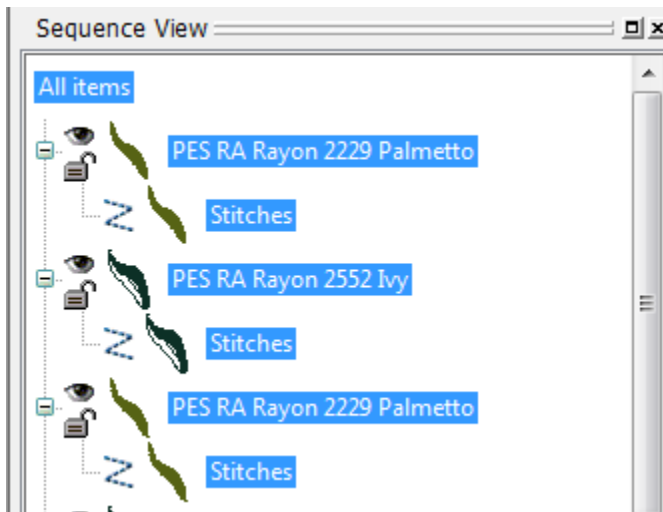

Repeat this step two additional times, until there are four leaf designs created.

6. Select All Items under Sequence View.



7. Click on the Center  tool on the top toolbar to center the design in the hoop.
8. To sort the colors in the design, click on the Color Sort  tool. A dialog box will open to show the number of colors that have been reduced.

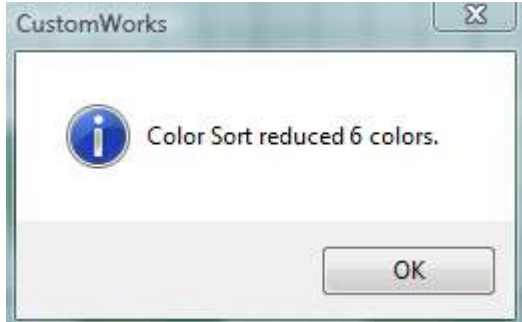

9. Click on File Save As and save as a Working File format (.blf). Give the design the name Block 1 and then save as a .pes file to the media device that your embroidery machine will read.
10. From the purple fabric, cut a piece that measures 5 ½" x 13 ½".
11. Hoop the Baby Lock Tear-Away stabilizer and spray with the temporary spray adhesive. Center and place the 5 ½" x 13 ½" piece in the hoop and finger press in place.
12. Embroider the design using the colors indicated. Set the finished embroidery aside for now.

### **Block 2:**

1. Click on New Page  and merge in the next design (*as shown below in the illustration below*).

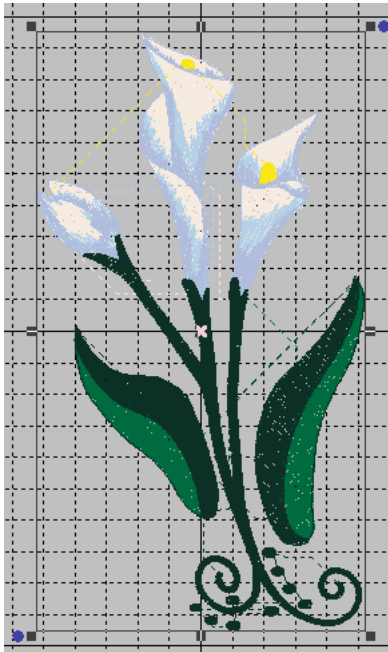

2. Select All Items under Sequence View and change the Height in the Properties to 190mm and click on Apply. SizeWorks is once again being utilized.

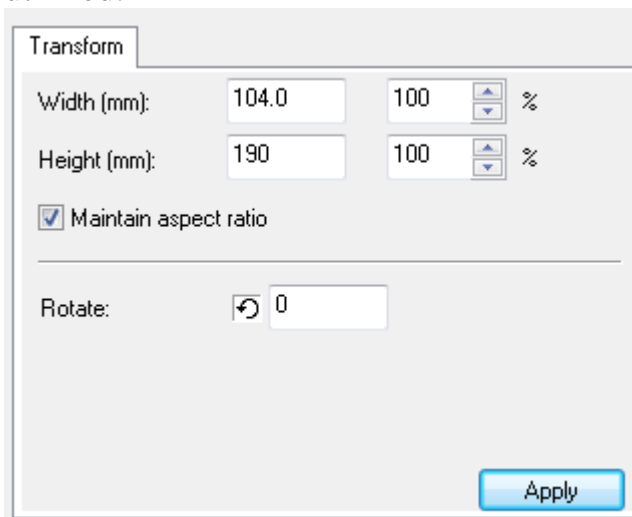

3. Center the design in the hoop with the use of the Center  tool.
4. Click on File Save As and save as a Working File format (.blf). Give the design the name Block 2 and then save as a .pes file to the media device that your embroidery machine will read.
5. From the purple fabric, cut a piece that measures 7 1/2" x 11 1/2".
6. Hoop the Baby Lock Tear-Away stabilizer and spray with the temporary spray adhesive. Center and place the 7 1/2" x 11 1/2" piece in the hoop and finger press in place.
7. Embroider the design using the colors indicated. Set the finished embroidery aside for now.

### Block 3:

1. No adjustments will be made to the design that is to be used in this block. From the purple fabric cut a piece that measures 5 ½" x 6 ½". Since the design is smaller, hoop the Baby Lock Tear-Away stabilizer using the 130mm x 180mm hoop and spray with the temporary spray adhesive. Center and place the 5 ½" x 6 ½" piece on the hoop and finger press in place.
2. Retrieve the smaller Lily design that measures 54mm x 98mm in the embroidery machine. (*See the illustration below for the design.*)
3. Embroider the design using the colors indicated. Set the finished embroidery aside for now.

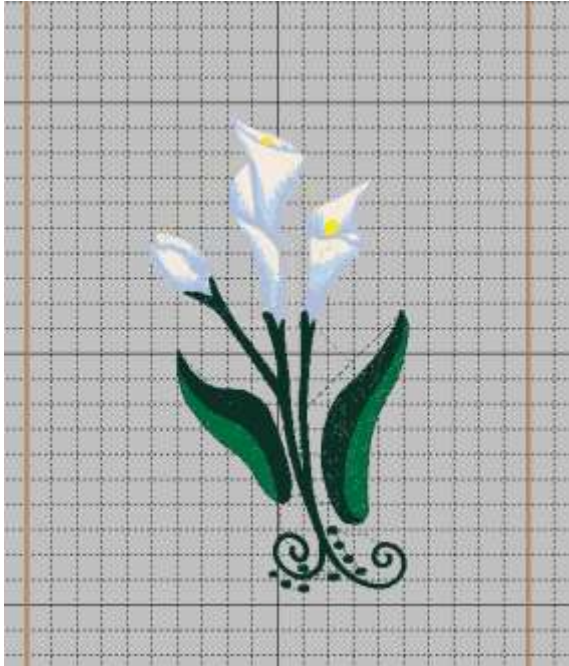

### Block 4:

1. The embroidery design used in this block will require no changes. From the purple fabric, cut a piece that measures 5" x 5 ½". Hoop the Baby Lock Tear-Away stabilizer using the 130mm x 180mm hoop and spray with the temporary spray adhesive. Center and place the 5" x 5 ½" piece in the hoop and finger press in place.
2. Bring the design onto the machine workspace that measures 62mm x 69mm. (*The design is shown in the illustration below.*)
3. Embroider the design using the colors indicated. Set the finished embroidery aside for now.

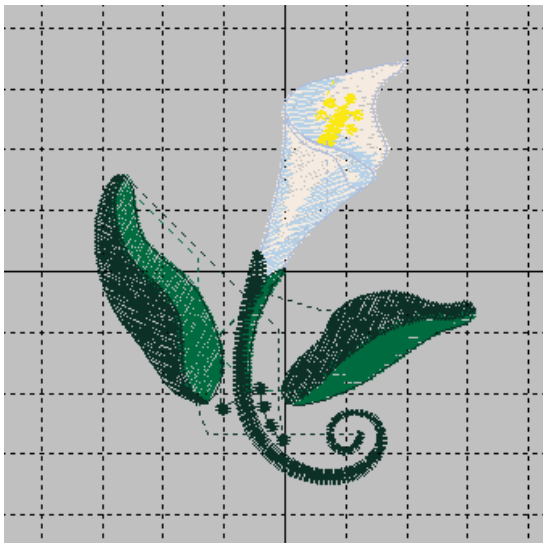

**Block 5:**

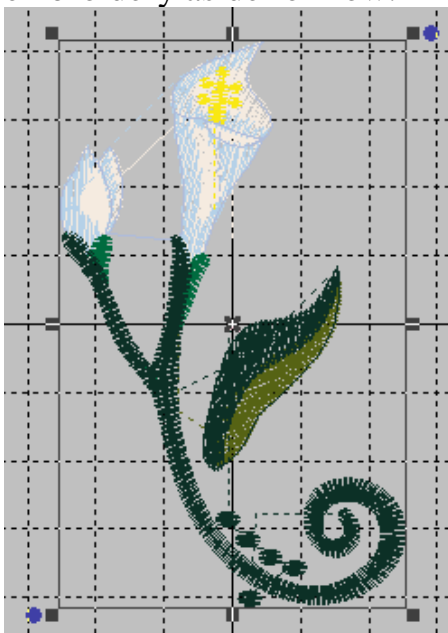

1. From the purple fabric, cut a piece that measures 5" x 5 1/2". Hoop the Baby Lock Tear-Away stabilizer using the 130mm x 180mm hoop and spray with the temporary spray adhesive. Center and place the 5" x 5 1/2" piece on the hoop and finger press in place.
2. Retrieve the Lily design that measures 50mm x 82mm in the embroidery machine. (*See the illustration below for the design.*)
3. Embroider the design using the colors indicated. Set the finished embroidery aside for now.

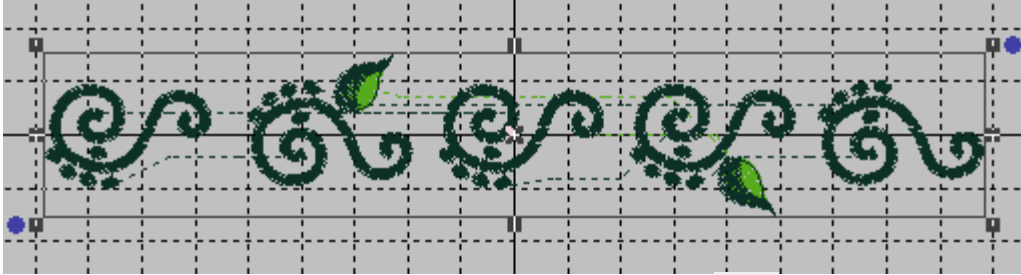

## Block 6:

1. On the computer click on New Page  in CustomWorks and merge in the next design (*as shown below in the illustration below*).



2. With the design selected, click on Rotate Right  tool.
3. Click on the Hoop  tool to place the hoop (200mm x 300mm) on the workspace. Since the hoop was selected during the same session, the hoop will be remembered.
4. To size the design, click on the Fit Hoop  tool on the top toolbar. This will resize the design so it fits in the hoop at its largest while recalculating the stitch count. The design should be approximately 298mm x 50mm. This again was the use of SizeWorks.
5. Click on File Save As and save as a Working File format (.blf). Give the design the name Block 6 and then save as a .pes file to the media device that your embroidery machine will read.

## Free Standing Leaves:

1. Hoop the Baby Lock Hydro Melt Topping in the 200mm x300mm hoop.
2. Spray the stabilizer lightly with the temporary spray adhesive and place a piece of white organza that is cut larger than the hoop on top of the hooped hydro melt.
3. Retrieve Block 1 design (leaves) and embroider the leaves using the same thread colors that were used previously. Embroider 18 leaves.
4. Gently remove the stabilizer from the leaves. To remove the organza, cut close to the edge on each of the leaves. Use a wood burning tool to melt the organza around the outer edges of each of the leaves. This helps to hold the leaves together and will also give the leaf shaping ability.

## Free Standing Lilies:

1. With the use of the prior customized designs in CustomWorks, click on the tab for Block 2. Since we need only one lily, several elements will be removed. To ungroup the areas in the design, right click on the design and from the list of commands select Ungroup.
2. Select the first green color under Sequence View and click on the Delete key on the keyboard to remove those segments. Select the second green

color under Sequence View and click on the Delete key to remove those segments.

3. All that remains are three lilies. The two on the left side will also be

removed in this step. Click on the Stitch  tool on the left toolbar. Left click and drag a box around the lily on the left. (*See the illustration that follows.*) All the stitch points that were inside the box are selected and show up as square boxes.

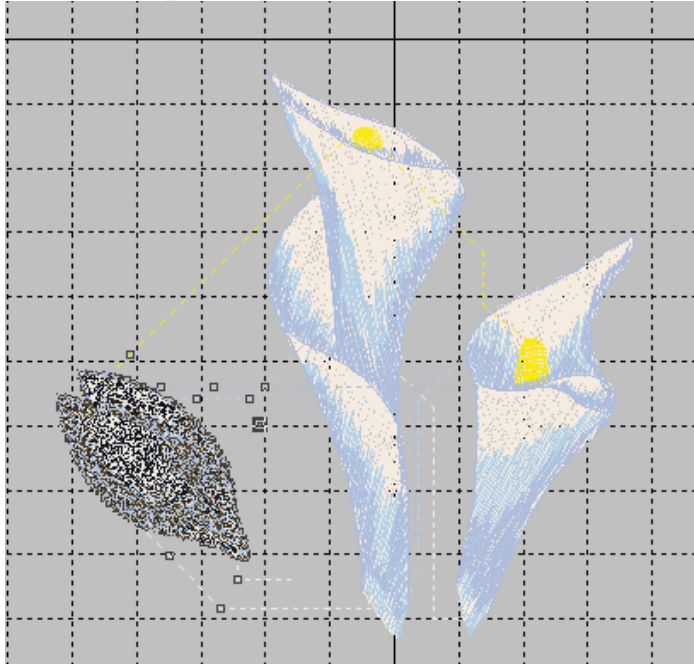

Click on the Delete key on the keyboard to remove the stitches. Repeat this step again until the second lily has all of its stitch points removed. (*See the following illustration for the finished lily.*)

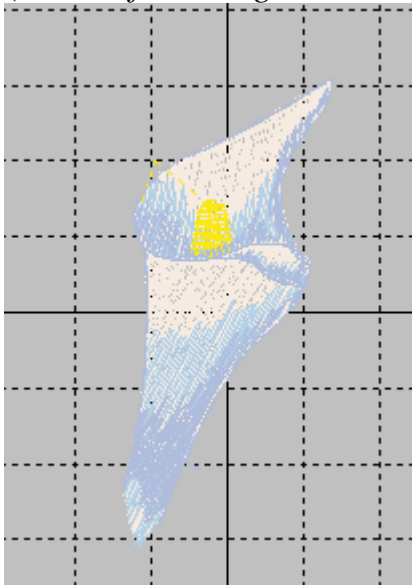

4. Click on File Save As and save as a Working File format (.blf). Give the design the name Lily and then save as a .pes file to the media device that your embroidery machine will read.

5. Hoop the Baby Lock Hydro Melt Topping in the 200mm x300mm hoop. Spray the Hydro Melt lightly with the temporary spray adhesive. Place a piece of white organza that is cut larger than the hoop on top of the hooped hydro melt.
6. Merge the Lily design onto the embroidery machines workspace and move the design to the outer edge of the hoop but within the sewing field. Merge additional Lily designs onto the sewing field and space the lilies evenly. Stitch a total of nine lilies. This may require additional hoopings.
7. After the lilies are embroidered, gently remove the stabilizer from the leaves. To remove the organza, cut close to the edge around each of the lilies. Use a wood burning tool to melt the organza around the outer edges of each of the lilies.

### **Assembly:**

1. At the cutting table, using a rotary cutter, cut from the dark green print fabric sections that are 2" larger all the way around than each of the embroidered sections. These pieces will be placed behind the purple embroidered sections.
2. Trim all of the edges on the embroidered pieces making sure that they all have straight edges.
3. Press all of the pieces.
4. Lightly spray with the back of the embroidered sections and place in the center of the corresponding dark green section.
5. Set the machine up for sewing and choose any decorative stitch.
6. Sew around the embroidered edge on each of the sections. Use a different decorative stitch for each of the sections.
7. From the light green print fabric, cut two pieces that measure 23" x 46". One of the pieces will be the front and the other will be the backing.
8. Lay one of the light green sections on a flat surface with the right side facing upward. Position the embroidered sections onto the light green piece (*as shown in the illustration that follows*). The blocks should be placed in the order that they were created while working from left to right.

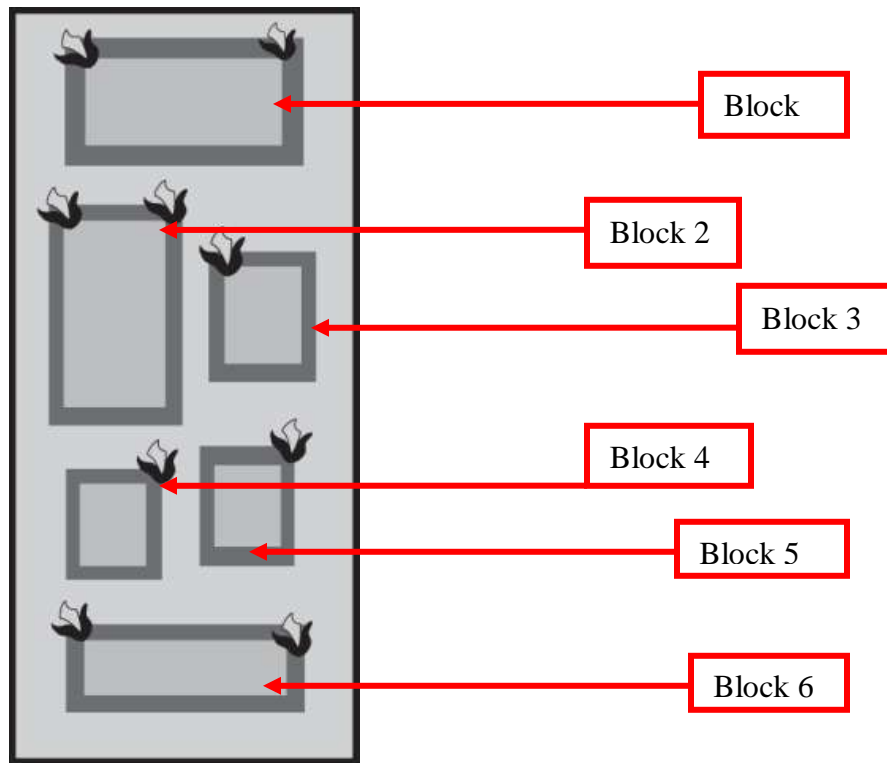

9. Lightly spray the back of each of the sections and finger press to secure in place.
10. Select a decorative stitch and sew the units to the main pieces of the wall hanging. Select different decorative stitches for each of the units.
11. Cut a piece of batting that is 2" larger around than the quilt top.
12. Layer the sections together to create a sandwich starting with the backing fabric placed face down, the batting in the middle and ending with the quilt top. To hold the sections together spray lightly between the layers with the temporary spray adhesive.
13. Quilt the wall hanging as desired using a stippling stitch.
14. Trim the quilt to measure 21" x 44".
15. Cut 2 ½" bias strips from the purple fabric and piece them together to create one continuous strip long enough to go around the perimeter of the quilt.
16. To bind the quilt fold the bias strip in half longwise with the wrong side of the fabric together. Starting on one of the long sides, pin the bias to the front of the quilt starting 6" down from the top. Using ¼" seam allowance, start to sew 4" down from the end of the bias strip. When you get to the corner stop sewing ¼" from the corner and cut the thread. Take the quilt top to the ironing table and fold the bias up so that the edge is even with the quilt edge (*as shown in the illustration below*). Fold the bias strip down so that the bias strip edge is lined up with the edge on the quilt (*as shown in the second illustration below*). Sew in this fashion around all of the remaining corners. When you get to the starting point, trim the end and tuck the end inside the bias starting point and finish sewing the bias strip to the quilt.

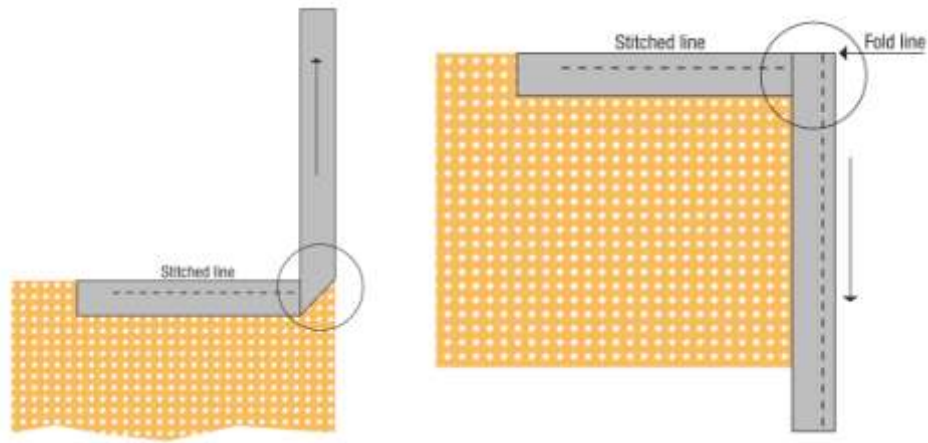

17. Fold the binding to the back and hand-stitch to secure the bias to the quilt top.
18. Place the free standing leaves and lilies in the corners (as shown in the flowing illustration). Hand-stitch them to the quilt.

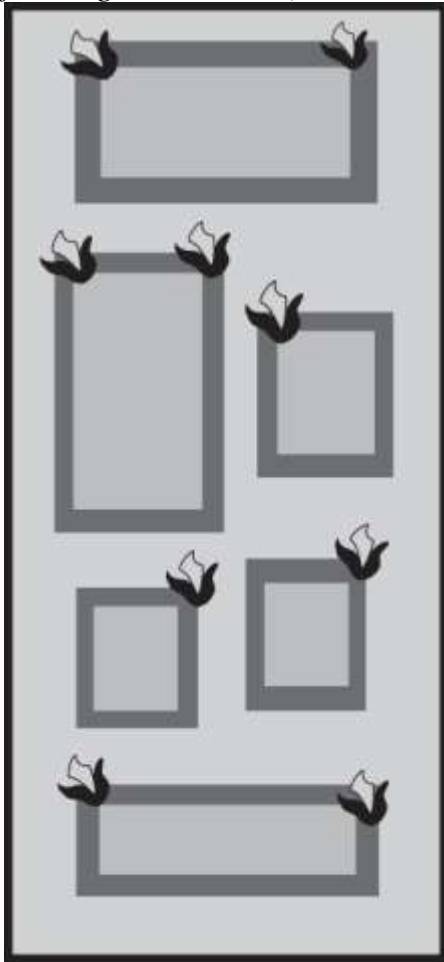

For other exciting projects like this one, visit our Web site at [www.designersgallerysoftware.com](http://www.designersgallerysoftware.com)